

Nora+ Controller

Product manual

2022-12-9



Disclaimer

Please read the content in this manual carefully before use to ensure that you can use this product correctly and safely. Please strictly follow the manual to install and use this product; our company shall not be liable for any damage or injury caused by improper use. For the needs of development and improvement, our company reserves the right to modify and refine product details and user instructions, and the relevant information shall be subject to the data provided by our staff. The content in this manual is provided based on the status of the product at the time of manufacture. Unless otherwise specified by applicable laws, our company makes no express or implied warranty of any kind regarding the accuracy, reliability and content of this document.

This product is only a pure hardware component for experimental unmanned systems, and the operating software is provided by a third party; moreover, we cannot control the user's intended use of the product. Our company only has the obligation to provide after-sales service within the product warranty period, and we do not provide reliability guarantees for any use cases. Our company shall not be liable for any direct, indirect, consequential, or accidental injury losses or penalties caused for any reason and under any circumstances. Once the product is used, it shall be deemed that you have recognized and accepted the contents of this statement.

Copyright©CUAV, Without permission, do not copy the contents or reprint.

Product version history

This product is a continuation version of CUAV Nora Pro controller, compatible with all the expansion hardware of the above products; except for the different compatible firmware, users can seamlessly replace it.

Online documentation

Please visit the CUAV docs for detailed tutorials and firmware downloads of this product:

<http://doc.cuav.net>

Download ground control station

[QGroundControl](#)











https://docs.qgroundcontrol.com/en/getting_started/download_and_install.html

[Mission Planner:](#)

<https://firmware.ardupilot.org/Tools/MissionPlanner/MissionPlanner-stable.msi>

Parts List

Nora+ Packing List

Nora+	X1	
I2C / CAN cable	X2	
ADC3.3 cable	X1	
RSSI cable(X7 series)	X1	
CAN PMU Lite Power Module	X1	
Dupont cable	X1	
CAN extension board	X1	
Pw-Link module	X1	
USB-TypeC cable	X1	
32G Memory card	X1	

Hardware specifications

Item	Parameter
------	-----------

Processor	STM32H743/ STM32H753
Accelerometer	ICM-42688-P ICM-20689 BMI088
Gyroscope	ICM-42688-P ICM-20689 BMI088
Compass	RM3100
Barometer	MS5611*2
Interfaces	
UART	5
I2C	6(2 integrated in GPS / uart 4 interface)
PWM output	14 (M1~M12 support dshot protocol)
RC in	1(Supports protocols such as PPM, SBUS, and DSM)
RSSI input	PWM or 3.3 analog voltage
CAN bus	2
Power input	2 (Power A is the common ADC power detection interface; Power C is the CAN ammeter interface)
Safety switch	1
GPS interface	2 (UART4 can be used as GPS2 interface)
Debug	1
JATG	1
USB 接口	2(1 x TYPE C , 1 x GH1.25)
Controller Working environment and physical Spec	
Operating voltage	4.5 ~ 5.5 V
USB input voltage	4.75 ~ 5.25 V
Servo input	0 ~ 10v
Operating temperature	-20 ~ 85°c
Size	85.5 x 42.0 x33.0mm
Weight	91g

Support firmware

Nora+ controller runs perfectly with ArduPilot 4.10/PX4 V1.12.3 and above firmware.

Firmware and source code

Nora+ supports PX4 and ArduPilot firmware. The compiled firmware is:

[Download and write firmware tutorial:](#)

<https://doc.cuav.net/controller/x7/zh-hans/ardupilot-users-manual.html#ardupilot-firmware>

If you want to modify the code; you can download the source code through the link below

[ArduPilot Github](#)

<https://github.com/ArduPilot/ardupilot>

[PX4 Github](#)

<https://github.com/PX4/PX4-Autopilot>

Compile firmware command(ArduPilot):

```
./waf configure --board CUAV-Nora //Compile CUAV-Nora branch firmware  
./waf copter --upload //Write the firmware to the controller
```

Compile firmware command(PX4):

```
make cuav_nora_default //Compile cuav_nora branch firmware
```

Pinouts

The design of the Nora+ interface uses Pixhawk standard pinouts. Please read the description of the interface definition carefully and use the original wiring of the product. If the wiring is not used according to the standard defined by the interface, the company will not compensate for the damage to the equipment.

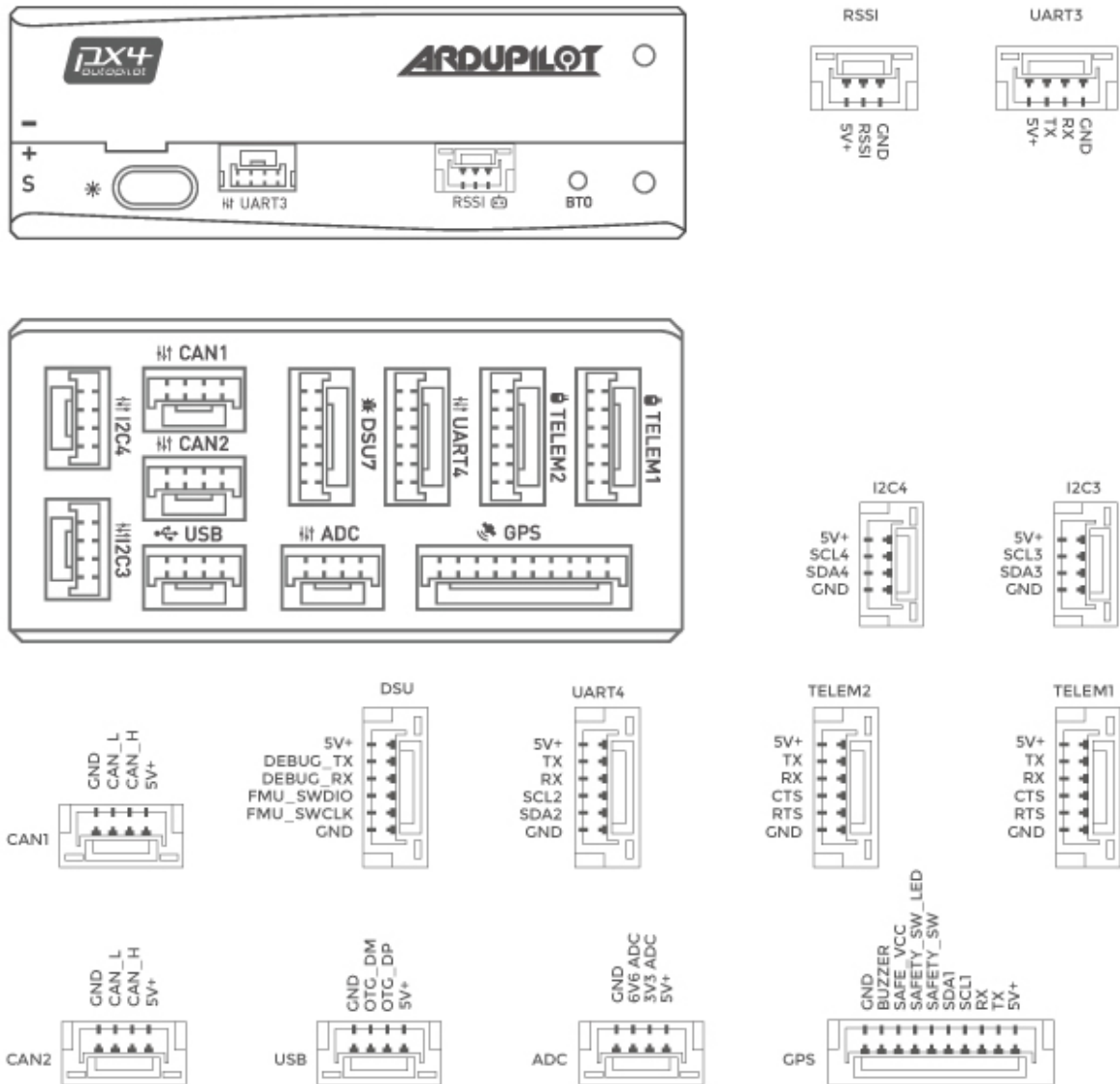

Hardware connection diagram

Take the quadcopter as an example:

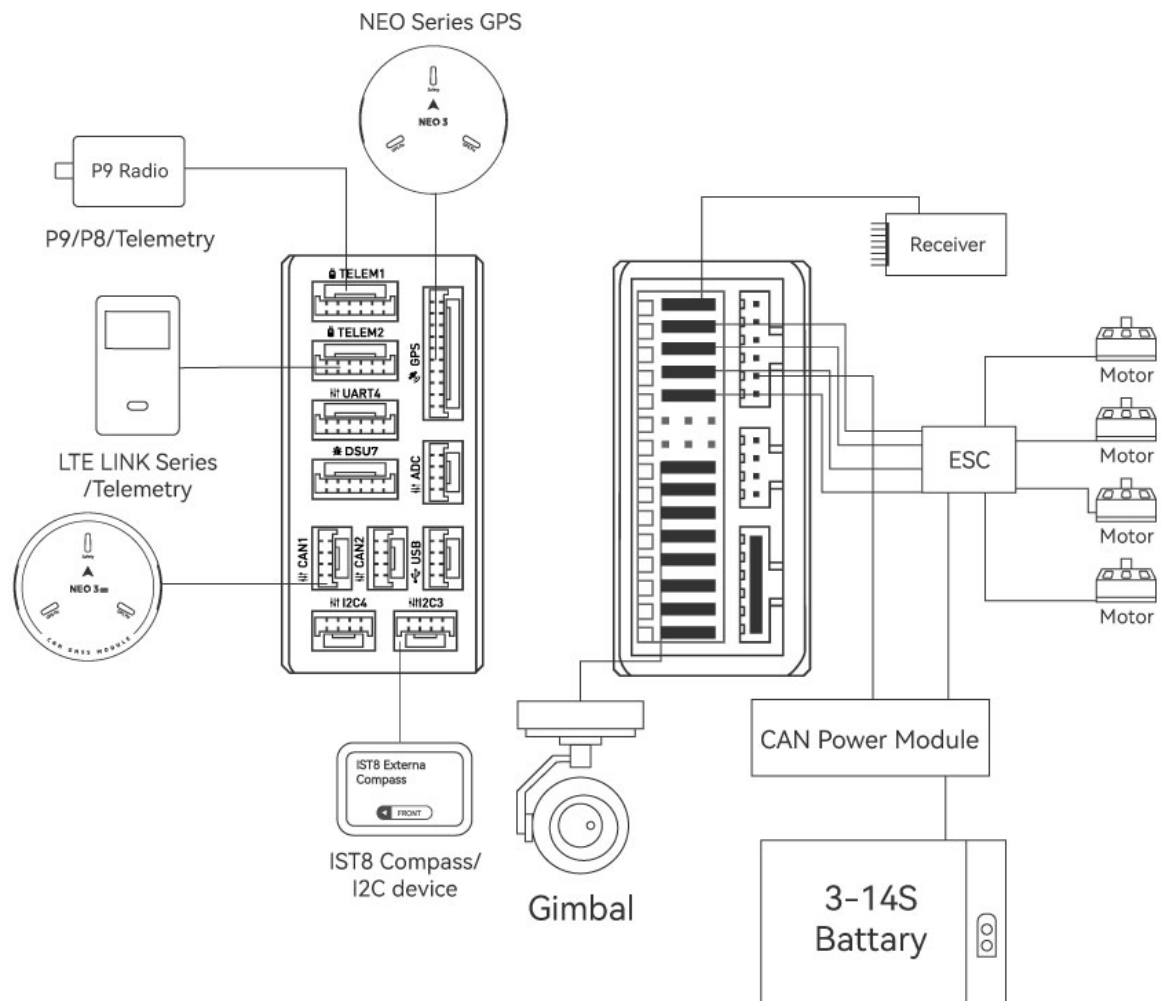

Product connection

Interface	Connected accessories
POWER A	Connect power module. Power input with analog voltage and current detection. Do not use a Digital PM on this connector!
POWER C	Please connect CAN PMU SE to this interface; this interface is connected to UAVCAN power module
GPS&SAFETY	Connect Neo series GPS or C-RTK 9P, including GPS, safety switch, buzzer interface.
UART 4	Can be used to connect to GPS, can be used as a second GPS
TELEM1/TELM2	Connect to the Telemetry System
TF CARD	SD card for log storage (card pre-inserted in factory).

M1~M14	PWM signal output port, which can be used to control motors or steering gears; and M1~M12 also support dshot protocol
DSU7	Used for FMU chip debugging, read DEBUG device information
TYPE-C(USB)	Connect to a computer for communication between the flight controller and the computer, such as loading firmware.
I2C1/I2C2/i2C4	Connect an I2C device such as an external compass.
CAN1/CAN2	Connect Dronecan devices such as CAN GPS.
RC IN	Including DSM, SBUS, RSSI signal input interface, DSM interface can be connected to DSM satellite receiver, SBUS interface to connect SBUS remote control receiver
RSSI	RSSI for signal strength return module

Certification



Product has passed
CE certification



Product has passed
CE certification



CUAV has passed
ISO 9001 quality management
system certification

More information

CUAV official website: www.cuav.net

For more usage and assembly instructions, please visit the document center: doc.cuav.net