

Raefly VT290 long endurance and load carrying uav

User manual

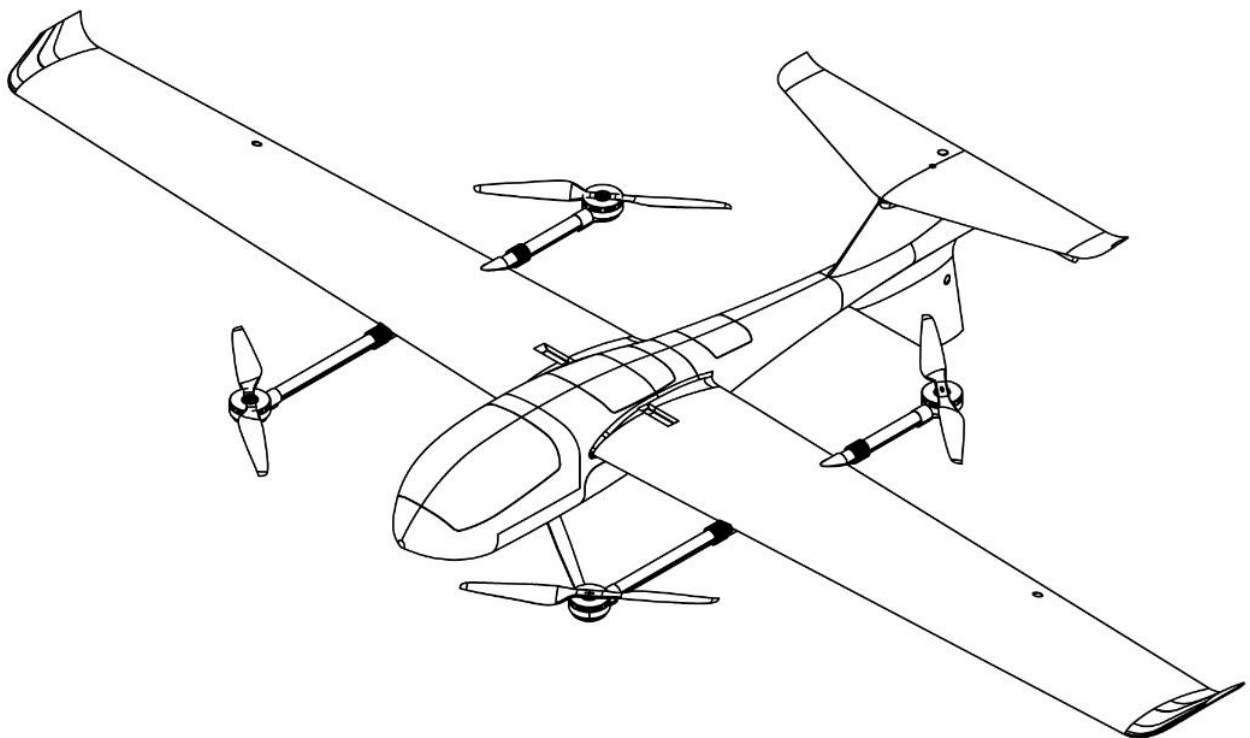

Raefly Tech Ltd

Disclaimer:

Strictly follow the manual installation and use of this product, and any improper use will result in damage or loss, for which our company is not responsible for any corresponding liability and compensation. As the configuration based on the version is continuously updated, Raefly Flying reserves the right to change the content of the manual according to system changes and work needs, without any guarantee of timeliness and accuracy of the document.

This product is a purely hardware product, and the software and firmware it runs are provided by third parties. We cannot control the user's usage purpose. Our company only provides after-sales service within the warranty period. Our company does not guarantee reliability for any purpose. We are not responsible for any losses, damages, penalties, or injuries resulting directly, indirectly, derivatively, or accidentally from any reason or situation. Once used, it is deemed to be an acceptance and acknowledgement of the content of this statement.

The copyright of this manual belongs to Raefly Tech. Unauthorized copying or reproduction of this manual is strictly prohibited.

Safety tips.

- Drone is not a toy, please conduct flight activities in accordance with local laws.
- No flying allowed in sensitive areas such as no-fly zones, airport control zones, military and administrative institutions, roads, and so on.
- Do not fly in severe weather conditions such as thunderstorms.

Table of contents

Safety tips.....	2
Package list.....	4
Assembly.....	4
Ground station download.....	7
Safety Overview.....	7
Safe operation.....	8
Pre-flight check.....	8
Code of Practice.....	8
Emergency measures.....	9
Mission planning.....	10
Introduction to common flight modes.....	11
Take off.....	12
Data sheet.....	15
Laws and regulations.....	16

Package list

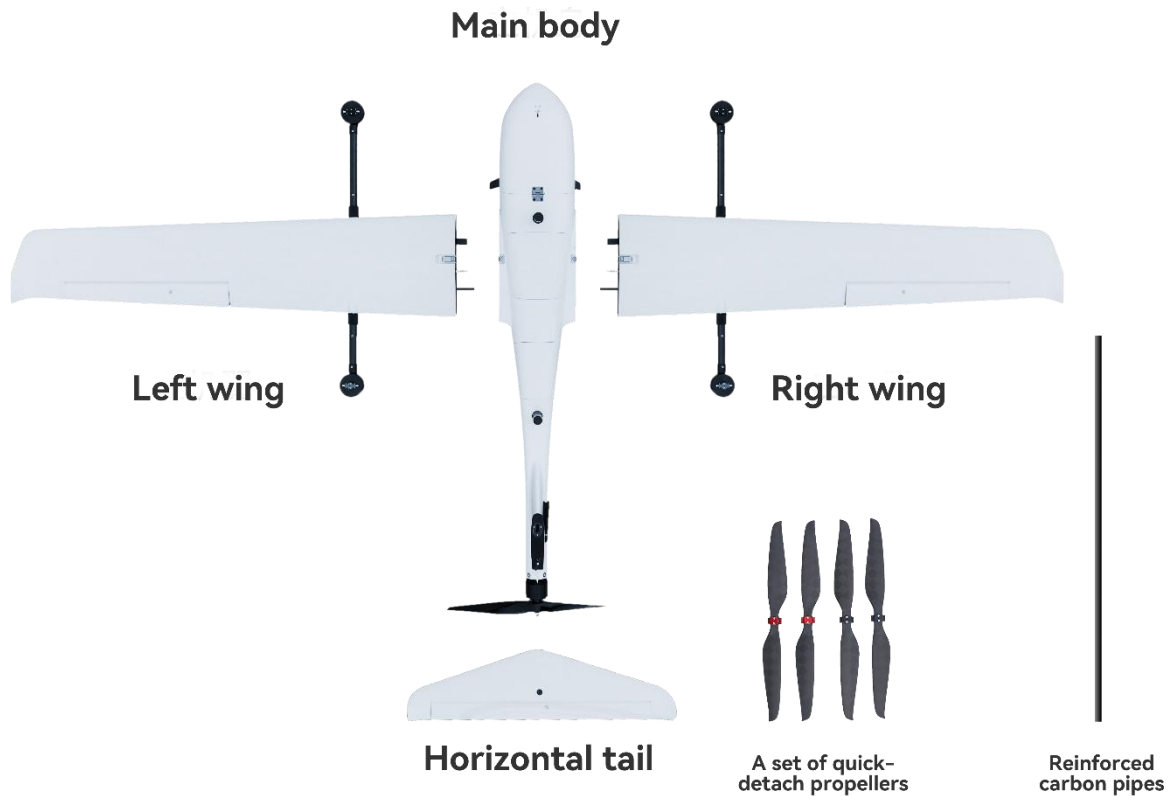

Assembly.

Installing the horizontal tail wing.

Pull the quick-release lever to protrude from the slot, and then install it into the ball head.



Align the horizontal tailfin with the circular screw hole, install it into the body, and then push the tailfin towards the nose to secure the screws in place.



Hand-tighten the screws into the tailfin and ensure they are secure.



Installing the ailerons:

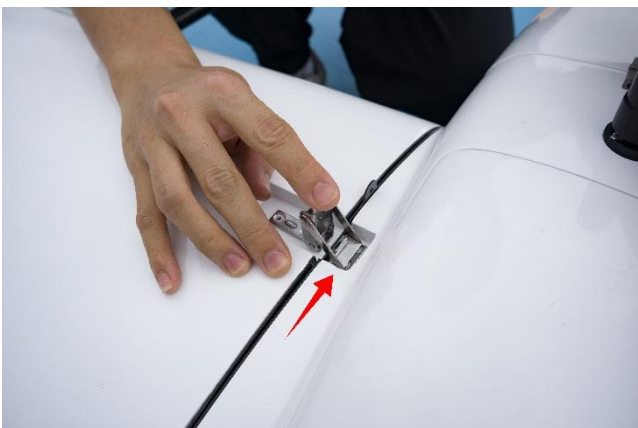
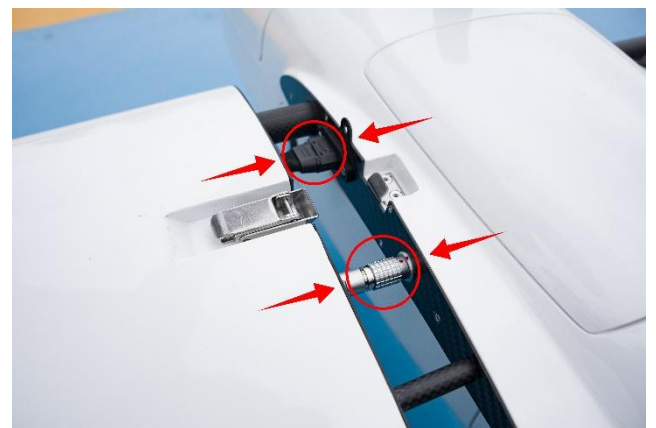
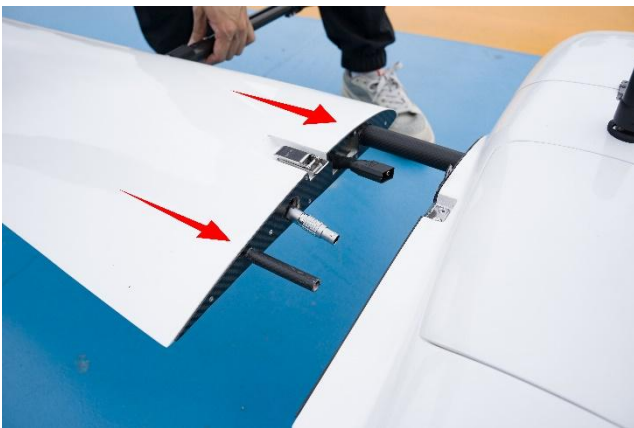

Installing propellers and payload compartments:

Insert the propeller with the attached propeller clamp into the quick-release propeller mount of the same color, and align the mission pod with the guide rail before installing it into the aircraft body.

**Tutorial(Video):**

Welcome to search for Raefly VT290 on YouTube for the full tutorial.

Ground station download

The ground station control software of Raefly VT290 is QGroundcontrol software (the Android remote control has pre-installed QGC ground station software), you can also go to <http://qgroundcontrol.com/> to download it.

Safety Overview

Before flying, please carefully read the information on safety requirements in this chapter to ensure safe and correct use of this product.

Safe operation

- Do not get close to rotating propellers and motors. Please make sure the drone motor is locked before approaching.
- Before taking off, make sure the power battery and remote control are fully charged, and ensure enough power for return during flight.
- Fly away from crowds and take safety precautions.
- Non-professional technical personnel are not allowed to disassemble or change the aircraft design, firmware program, and parameter configuration without authorization; otherwise, serious damage will result.

Pre-flight check

Please perform necessary flight inspections before flying.

- Inspection of the stability of propellers, motors, wing buckles, wings, servos, and servos motor signal lines
- Check motor steering and working status
- Power battery, ground station power supply, link check
- Confirm flight mode, route and GPS status check

Code of Practice

- After signing for the items, please confirm in time whether the items are complete, whether there are damages and stability damages caused by transportation, etc.
- The first flight should be operated by flight personnel with professional technical ability, carefully and strictly implement the pre-flight inspection procedures before the flight, and make a safe flight plan.
- **Flight crew members: operator, co-operator.** The operator (pilot) is responsible for the safety of the UAV during operation, and it is necessary to ensure the flight operation specifications and adopt correct flight emergency measures to ensure flight safety. When the operator is performing remote control flight, the assistant operator will detect the UAV status through the ground station, and report the UAV status information such as flight altitude, flight speed, airspeed and fault alarm to the operator at high speed.
- Before flying, one should be familiar with the local environment, especially the terrain, the height of buildings, and the layout of power/communication grids, etc., to prevent property damage caused by collisions during flight.

Emergency measures

- When an alarm message appears on the ground station before flight, you should troubleshoot according to the prompt message. If you cannot identify the alarm, please contact our technical personnel. Do not force takeoff with a fault. When flying, if an emergency alarm message appears, please immediately jump to the guided landing route or take emergency landing measures to land the drone to a safe area for troubleshooting.
- Emergency rescue measures:
 - **If a malfunction occurs in the fixed-wing mode (such as encountering strong winds or damage to the forward power components), switch to the quad-rotor mode (Q_Loiter/Q_Hold) mode and make an emergency landing to a safe area.**
 - **When the GPS is lost or GPS spoofing occurs, use the ground station or remote control to switch to Q_Hold mode. If you have fixed-wing flying experience, you can switch to FBWA mode to take over control of the drone.**

Battery safety instructions



- The battery is strictly forbidden to come into contact with liquid or other objects that are likely to cause a short circuit, and it is strictly forbidden to use the battery in wet weather, otherwise it may cause spontaneous combustion or self-explosion.
- It is strictly forbidden to use overcharge, overdischarge, bulge, leakage, and package damaged batteries.
- Do not disassemble or pierce the battery with sharp objects in any way.
- It is forbidden to charge when unattended. If the battery catches fire, use sand or dry powder fire extinguisher to extinguish the fire
- After using a battery, charging should be performed after the battery has returned to room temperature, otherwise it will affect the battery lifespan.

Note:

- When storing for an extended period of time, it is recommended to discharge the battery to 3.7V per cell (6S battery 22.2V, 12S battery 44.4V).
- The commonly used battery for this product is a semi-solid or all-solid battery. The empty voltage is 2.5V/cell, and it can be discharged to 3.1V/cell in general, and the lowest 37V for 12S batteries. Insufficient battery power will cause the drone to crash, and it is necessary to reserve enough power to return to the flight.
- This product is commonly configured with a battery with a discharge rate of 10C and a standard charge rate of 1C. Taking a 30000mAh battery as an example, the maximum charging current can be set to 30A. Using the battery beyond the specification will cause damage to the battery or even the drone.

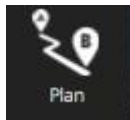
Mission planning

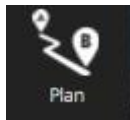

Click  icon, Enter the plan interface, click the icon  Add the takeoff command and set the altitude at which takeoff starts to convert to fixed wing.



Click , Place a guide conversion waypoint (upwind conversion) at a distance of more than 300 meters in front of the wind, and set the flight altitude according to actual needs (it is recommended to be slightly higher than the conversion altitude).

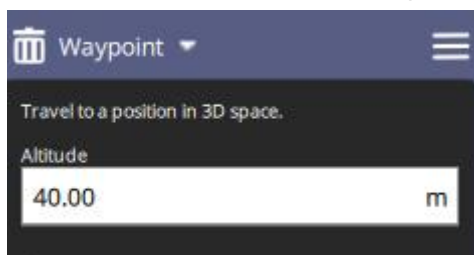

Add a hover and climb waypoint, climb to the target altitude and enter the normal mission route.



After executing the guided takeoff route, add waypoints in the target area according to mission requirements

After the mission waypoint is over, add appropriate waypoints to guide the aircraft to return to the vicinity of the landing point on a safe path. Place a hover drop point in a safe area, set the altitude to a lower value



Finally place a drone transition point in the area near the landing point with the altitude set to a low value.

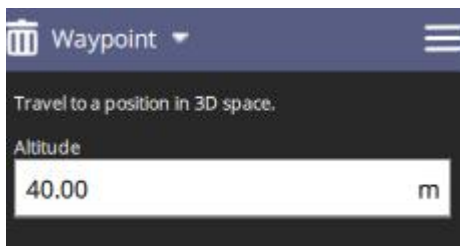

When the drone reaches this point, it will automatically switch to Q_RTL mode and land at the Home point.

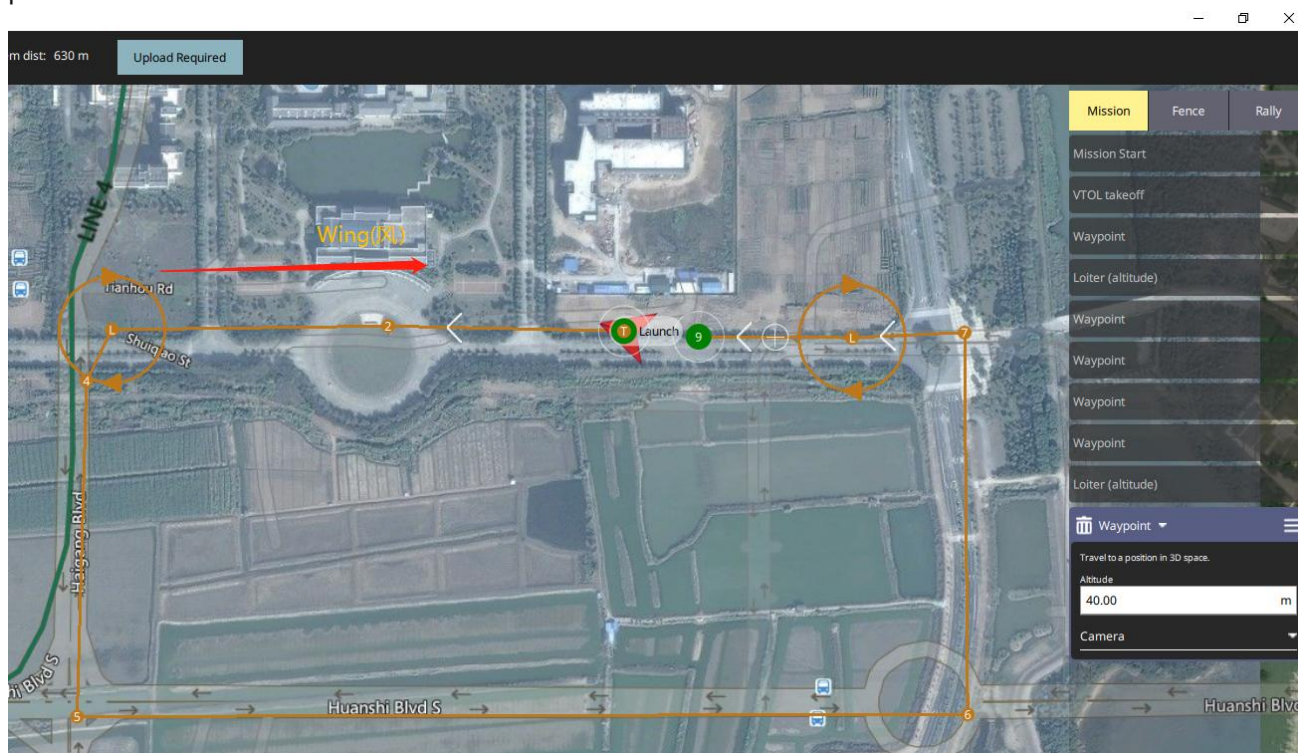

Note: It is recommended to switch to headwind for takeoff and landing, to ensure that there is enough lift for safe transition during the transition.

Introduction to common flight modes

All modes starting with Q_ are multi-rotor modes (vertical motor rotation), and those without Q_ are fixed-wing modes (forward motors work)

The commonly used multi-rotor modes are:

- **Q_Loiter:**The aircraft is flying in Copter Loiter mode, and both the throttle and pitch control sticks are returned to the center, and the drone will hover in the air and maintain its position.
- **Q_Hold:** The aircraft is flying in Copter Althold mode , Set the throttle stick to the middle position, the drone will maintain the altitude, but not the position, you need to try to control the position through the joystick.
- **Q_Stabilize:** The aircraft is flying in Copter Stabilize mode,The height and attitude are controlled by the control stick, which requires real-time control of the drone's attitude (but the aircraft can maintain a balanced attitude when the stick is not moved)
- **FBWA:** It is the most commonly used fixed-wing flight mode. In this flight mode, the aircraft will maintain the pitch of the roll machine specified by the joystick, but will not maintain the altitude. The increase and decrease of the aircraft's altitude depends on the airspeed. If you need to maintain the altitude, Please use FBWB mode.
- **FBWB :** Similar to FBWA mode, but the aircraft will maintain altitude, pitch and roll are controlled by the joystick, and the throttle control stick controls the target airspeed.

Take off

- 1) Turn on the remote control of the drone and place the antenna of the remote control correctly.
- 2) After installing the battery and confirming that the center of gravity is balanced, connect the battery.



Center of gravity:

The ear hanging holes shown below are the reference points for measuring the center of gravity.

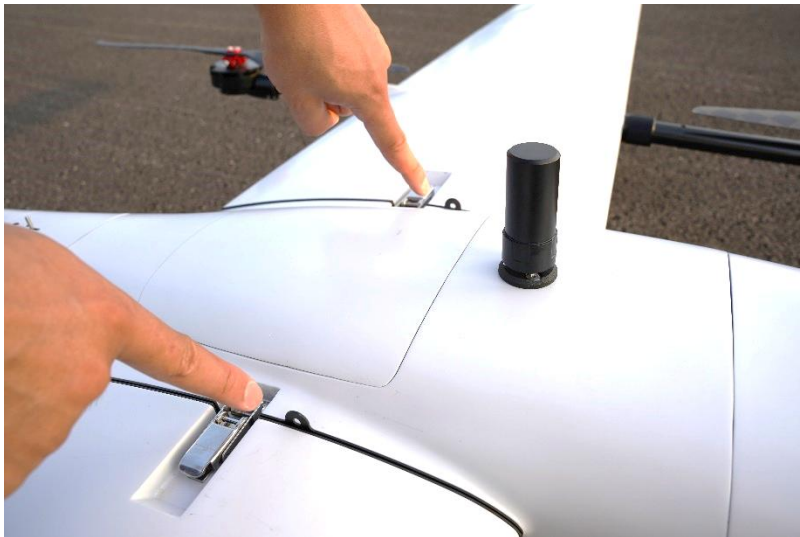

Use the rope to lift the aircraft and measure the center of gravity. Keep the aircraft level by adjusting the front and rear position of the battery. When pulling up from the center of gravity measurement point, if the front and rear are balanced or the machine head is slightly raised, the adjustment is successful.



Note: The position of the center of gravity will affect the flight stability and flight efficiency. Before flying, it is necessary to confirm the balance of the center of gravity

- 3) Turn the drone mode lever, and after confirming that the flight mode is correct, switch the mode to Q_Lotiter mode; pull the throttle stick to the lowest position, pull the direction stick to the rightmost position, and wait for the drone to arm.
 - 4) Keep the throttle stick above the neutral position, the aircraft will take off vertically, keep the throttle stick in the neutral position, the drone will maintain the altitude, and at the same time keep the pitch and roll joystick in the neutral position, the drone will hover in the air to maintain the position.
 - 5) If you need the aircraft to perform route tasks (you need to write route tasks before flying), you can switch the flight mode to AOTU mode, and the aircraft will automatically climb to the converted altitude and then automatically switch to fixed-wing mode., No human intervention is required.
 - 6) 6) If you need the aircraft to perform route missions (the waypoints need to be written into the flight controller before flying), you can switch the flight mode to AOTU mode. The aircraft will automatically climb to the conversion altitude and then automatically convert to fixed-wing mode.
- No need for human operation**
- 7) Fully automatic mission operation:
After writing the waypoint into the flight control, switch to AOTU mode and slide the icon to the right.

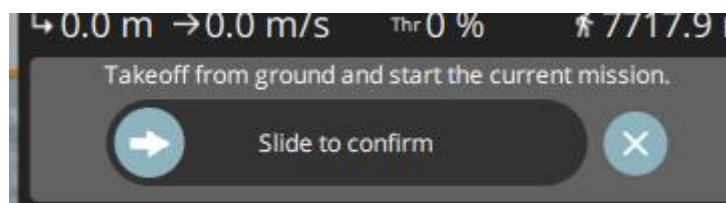

After the drone automatically unlocks and climbs to the specified altitude, it converts to fixed-

wing mode (autonomous conversion, no operation required).The operator should remain vigilant and monitor the status of the aircraft.

Data sheet

Product Attributes	Small Electric VTOL
Material	Carbon Fiber Composite Material
Power Form	12S battery powered
Wingspan	2900mm
Delivery mechanism	No
Empty Weight	13.5kg
MTOW	19kg
Payload	5kg
Battery life	3h@1.5kg (Calm wind at sea level)
Wind Resistance	Level 5
Flight Speed	20-35m/s
Geofence	Flight Altitude Limit / Airport No-Fly Zone / Temporary No-Fly Zone Flight Area Restriction
Unique Code	Support remote ID (tamper-proof) and broadcasting
Equipped with data link	10KM All-in-One Android Remote Controller Data Link
Fail-Safe	Battery low voltage protection, link disconnection protection, altitude protection
Takeoff and Landing Mode	VTOL
Application	Aerial Surveying and Mapping, Power Inspection,

	Agriculture and Forestry Detection
Operating Temperature	-20°C to 50°C

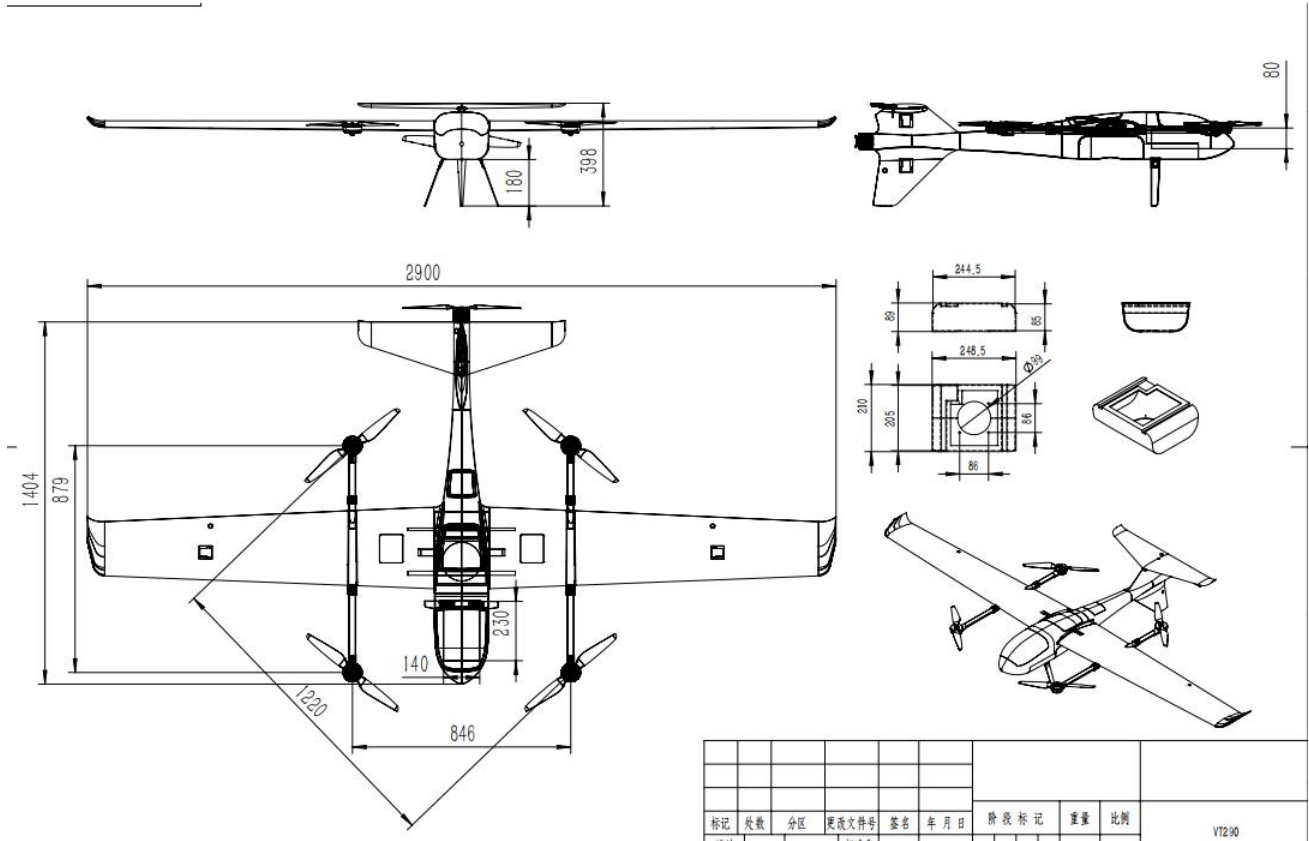

Laws and regulations

- Everyone should be familiar with and consciously abide by local laws and regulations, and perform real-name registration, nationality registration and other procedures.
- When the number of flight sorties reaches 500, system maintenance is required to replace vulnerable components such as steering gear, propellers, and damaged wires.
- After use, it is necessary to remove surface debris in time to prevent the fuselage from being corroded
- Do not use it near wet or highly corrosive substances. When using it in high-salt environments such as rivers and seaside, it is necessary to clean the fuselage in time to prevent corrosion of screws, fuselage and other parts. Corroded parts should be replaced in time.
- Do not use in low temperature below -20°C or high temperature environment above 60°C
- In dusty and rainy weather, protective measures should be taken, and special checks should be made to see if the pitot tube is blocked.